



## **Starting Line Products, Inc.**

743 Iona Rd. Idaho Falls, ID 83401, (208)529-0244 Fax (208)529-9000

# **Clutch Alignment Tool**

**Part Number 20-191**

**For Polaris models with Rapid Reaction Secondary Clutch**

**TSS-98, TSS-04, Tied and P2**

**not for Rush, Pro Ride or Axys Chassis Models**

### **TSS-98 Instructions for 2005 and older Polaris except IQ**

1. Adjust belt deflection to 1.25". (Refer to Polaris service manual for further instructions on belt deflection)
2. Remove drive belt.
3. Install notched end of clutch alignment tool (marked **B** in the diagram) over the fixed sheave of the primary clutch (marked **A** in the diagram). Set arm of alignment tool (marked **C** and **D**) so that it lies flush with the outboard of the secondary clutch (marked **E**).

#### **Alignment specification without SLP Torque Arm/Push Arm**

When alignment is correct, there should be a gap of .040" between point **D** on the alignment tool and the outboard of the secondary clutch. Between point **C** on the alignment tool and the outboard side of the secondary clutch, there should be no gap .

#### **Alignment specification with SLP Torque Arm/Push Arm**

When alignment is correct, there should be a gap of .000" to .020" between point **D** on the alignment tool and the outboard side of the secondary clutch. Between point **C** on the alignment tool and the outboard side of the secondary clutch, there should be no gap .

4. If after checking clutch alignment it has been determined that an adjustment at point "**D**" is needed, it can be done by loosening all motor mounts and gradually twisting the motor until the desired alignment is achieved. If an adjustment at point "**C**" is needed, it can be done by adding or removing jack shaft shims.
5. Tighten all mounts back to the manufacturer's specification.
6. Adjust secondary clutch side to side free play on jackshaft. Optimum free play should be between .020" and .040". This can be checked by measuring the amount of movement that the secondary clutch has when mounted on the jack shaft. Adjustments can be made by adding or removing jack shaft shims or clutch bolt shims.

## **TSS-04, Tied and P2 Instructions** for 2005 and older Polaris except IQ

1. Adjust belt deflection to 1.25". (Refer to Polaris service manual for further instructions on belt deflection)
2. Remove drive belt.
3. Install notched end of clutch alignment tool (marked **B** in the diagram) over the fixed sheave of the primary clutch (marked **A** in the diagram). Set arm of alignment tool (marked **C** and **D**) so that it lies flush with the outboard of the secondary clutch (marked **E**).

### **Alignment specification without SLP Torque Arm/Push Arm**

When alignment is correct, there should be a gap of **.140"** between point **D** on the alignment tool and the outboard of the secondary clutch. Between point **C** on the alignment tool and the outboard side of the secondary clutch, there should be **.100"** gap .

### **Alignment specification with SLP Torque Arm/Push Arm**

When alignment is correct, there should be a gap of **.100" to .120"** between point **D** on the alignment tool and the outboard side of the secondary clutch. Between point **C** on the alignment tool and the outboard side of the secondary clutch, there should be **.100"** gap .

4. If after checking clutch alignment it has been determined that an adjustment at point "**D**" is needed, it can be done by loosening all motor mounts and gradually twisting the motor until the desired alignment is achieved. If an adjustment at point "**C**" is needed, it can be done by adding or removing jack shaft shims.
5. Tighten all mounts back to the manufacturer's specification.
6. Adjust secondary clutch side to side free play on jackshaft. Optimum free play should be between .020" and .040". This can be checked by measuring the amount of movement that the secondary clutch has when mounted on the jack shaft. Adjustments can be made by adding or removing jack shaft shims or clutch bolt shims.

## **TSS-04, Tied and P2 Instructions** *for 2005-11 Polaris IQ*

1. Adjust belt deflection to 1.25". (Refer to Polaris service manual for further instructions on belt deflection)
2. Remove drive belt.
3. Install notched end of clutch alignment tool (marked **B** in the diagram) over the fixed sheave of the primary clutch (marked **A** in the diagram). Set arm of alignment tool (marked **C** and **D**) so that it lies flush with the outboard of the secondary clutch (marked **E**).

### **Alignment specification with or without SLP Torque Arm/Push Arm**

When alignment is correct, there should be a gap of **0.125"** between point **D** on the alignment tool and the outboard side of the secondary clutch. Between point **C** on the alignment tool and the outboard side of the secondary clutch, there should be **0.085"** gap .

4. Adjust secondary clutch side to side free play on jackshaft. Optimum free play should be between .020" and .040". This can be checked by measuring the amount of movement that the secondary clutch has when mounted on the jack shaft. Adjustments can be made by adding or removing jack shaft shims or clutch bolt shims.

Figure 1

**TSS-98**

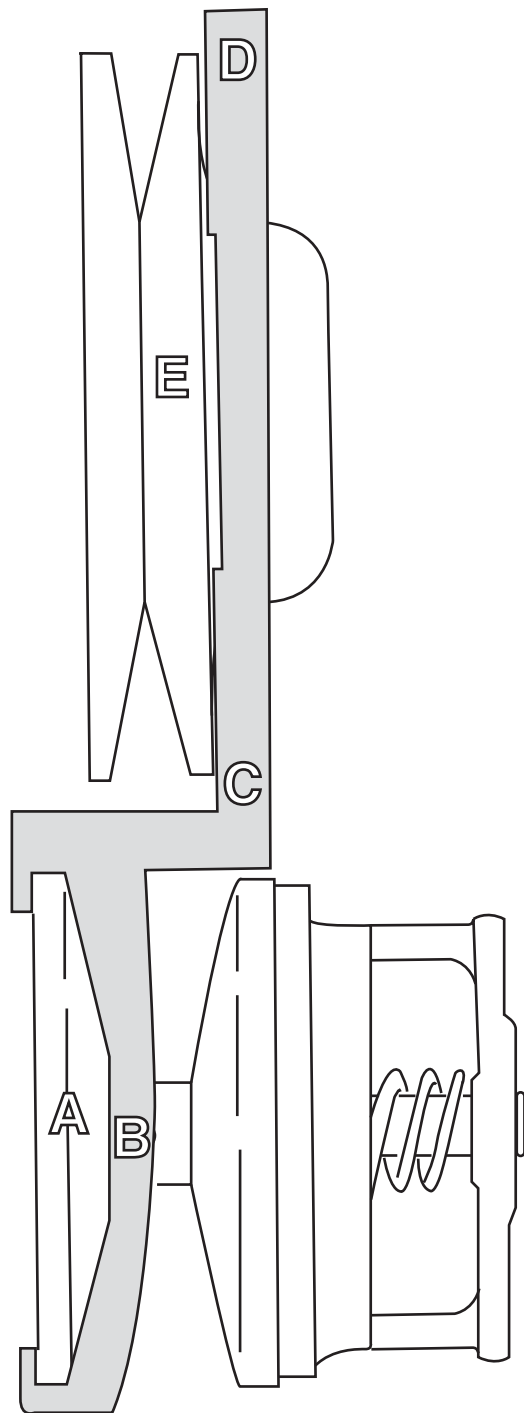

**TSS-04 / Tied**

